



Vertex Water Features

Lake Aeration Systems & Floating Fountains

With
Vertex
MicronBubble™
Technology

B O T T O M A E R A T I O N



AIR 1XL™

The Vertex Air 1XL™ pond aerator is a super-efficient, affordable and safe system. In a typical pond with 8 foot depths, an Air 1XL™ can aerate approximately 1-2 acres depending on shape, slope, oxygen demand and other factors. A 1/3 hp Brookwood™ SafeStart™ compressor, housed in our rustproof aluminum outdoor cabinet, feeds a bottom mounted CoActive AirStation™ utilizing Vertex's MicronBubble™ technology. The rising force of millions of bubbles circulates the entire water column, entraining bottom water up to the surface allowing vital oxygen to be absorbed and poisonous gasses expelled.

With no electricity in the water, Vertex's aeration systems are safe for any type of water recreation. Our systems have a full two-year warranty plus a five-year warranty against rust and corrosion on the cabinet, five-year warranty on the AirStations™ and a 15-year warranty on BottomLine™ supply tubing.

FEATURES

AIRSTATIONXL™

- ◆ Independently tested pumping rate, up to 9,286 GPM
- ◆ Four 9" flexible membrane discs with MicronBubble™ technology
- ◆ Self-cleaning, low maintenance & 5 year warranty
- ◆ Rugged EPDM construction
- ◆ Vacuum formed and sonic welded HDPE base unit
- ◆ Lipped edge prevents sinking into soft bottom sediments
- ◆ Five-year warranty

BROOKWOOD™ COMPRESSOR

- ◆ Two-year Vertex warranty
- ◆ Vertex SafeStart™ Technology
- ◆ U.L., 115 volt, 30 PSI
- ◆ Thermal overload protection
- ◆ 1/3 hp for low electrical costs
- ◆ 2-3 year extended duty cycle between scheduled maintenance

QUIETAIR™ AIR 1XL CABINET

- ◆ Class "A" GFCI protection on all circuits
- ◆ Powdercoated aluminum for a durable attractive finish
- ◆ High capacity 140 CFM fan
- ◆ Easy access design with barrel lock for security
- ◆ Easy plug-in connection to waterside electrical service
- ◆ Heavy duty mounting pad included
- ◆ 5-year warranty

BOTTOMLINE™ TUBING

- ◆ Over-sized 0.58" ID for high flow
- ◆ Heavy duty wall thickness for durability
- ◆ Self-weighted for easy installation
- ◆ Available in 100 and 500 feet increments
- ◆ 15-year Vertex warranty

BENEFITS TO THE LAKE

- ◆ High, independently tested pumping rate
- ◆ Entire water column circulated
- ◆ Increased oxygen levels throughout water column
- ◆ Elimination of low oxygen fish kills
- ◆ Reduced nutrient levels and associated algae growth
- ◆ Oxidized/reduced bottom muck
- ◆ Improved fisheries by expanding oxygenated habitat
- ◆ Reduced aquatic midge and mosquito insect hatches
- ◆ Elimination of foul odors from undesirable dissolved gasses
- ◆ Safe entry - no electricity in the water
- ◆ Extended warranties on all system components

SPECIFICATIONS: AIR 1XL™ LAKE AERATION SYSTEM

BROOKWOOD™ COMPRESSOR

1/3hp, 115v, Single Phase piston type compressor. Shall be built for continuous 24/7 operation and equipped with Vertex SafeStart™ technology allowing auto restart under maximum rated pressure without motor damage. Super-duty Brookwood™ compressors incorporate upgraded rotors, stators, valve plates, bearings and capacitors and are thermally protected, oil-free, and require no lubrication; just periodic cleaning of included washable air filter. Extended duty cycle shall be approximately 24 to 36 months for compressor maintenance, about 2 to 3 times the duty cycle of ordinary piston and rotary vane compressors. All Brookwood™ SafeStart™ compressors shall have a two year warranty.

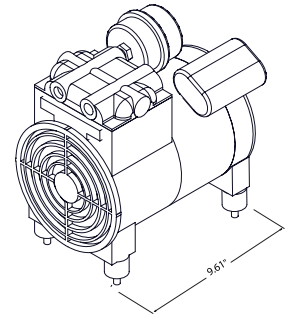

QUIETAIR™ AIR 1XL CABINET

Cabinet shall be constructed of aluminum with gray electrostatically bonded powder coating. Equipped with a stamped ventilation grill, engineered fan plenum, directed exhaust and an integral cooling fan producing 140 CFM to guard against excessive compressor operating temperatures. Cabinet shall be equipped with Class "A" GFCI Protection on both the compressor and fan circuits. Shall have a two-year warranty on all cabinet components including compressor, cooling fan and GFI and a five-year warranty against cabinet rust and corrosion.

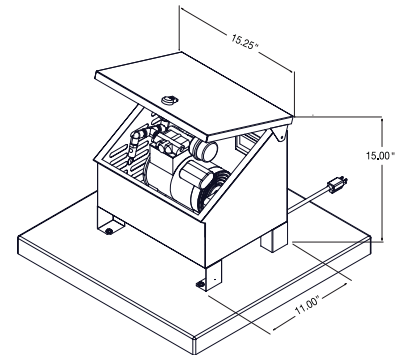

AIRSTATIONXL™ ASSEMBLY

Each AirStationXL™ shall consist of four self-cleaning, 9" diameter flexible membrane diffusers of EPDM compound with 100% rebound memory, each producing millions of fine 500 to 3000 micron bubbles. Each diffuser station shall be equipped with a vacuum-formed HDPE base; sonic spot-welded to provide unit integrity. Base unit (17.25"L x 13.25"W x 3.35"D) shall have a hollow chamber design for the addition of gravel ballast and a lipped design to prevent settling into soft bottom sediments. AirStations shall be independently tested and verified to provide stated pumping rates and have a five year warranty.

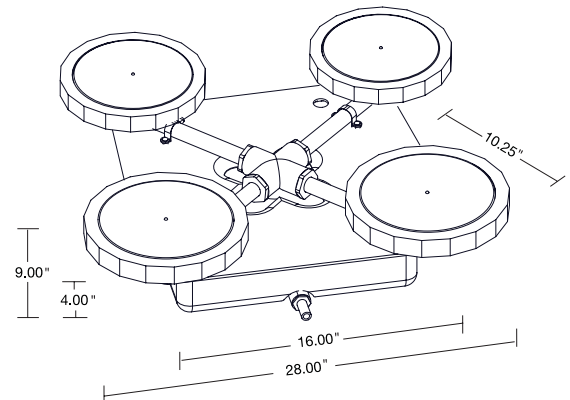

BOTTOMLINE™ SUPPLY TUBING

Self-weighted, direct burial submersible tubing for connection from compressor to diffuser stations. Tubing shall be flexible PVC composite construction for use with standard PVC solvent weld cement and 0.5" insert fittings. Tubing shall have a smooth walled, 0.58" I.D. for extra high flow rates with minimum friction loss to reduce backpressure and extend compressor life. Shall have a 0.235" tube wall thickness to provide long-term durability and protection against kinking and punctures. BottomLine™ tubing shall remain flexible in cold temperatures allowing for easy year round installations.

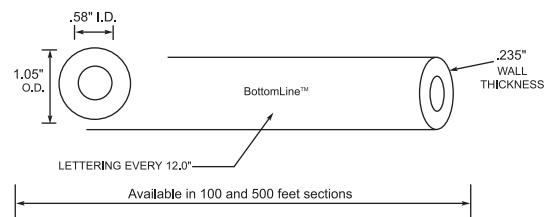

(800) 432-4302 / Fax (954) 977-7877
www.vertexwaterfeatures.com / e-mail: info@vertexwaterfeatures.com

Install all electrical equipment in accordance with Article 680 of the National Electrical Code and all local codes. Vertex Water Features reserves the right to improve and change our designs and/or specifications of our aerators without notice or obligation.
© 2007 Vertex Water Features