



Vertex Water Features

Lake Aeration Systems & Floating Fountains

**New
Model**

F L O A T I N G F O U N T A I N



AERATIONJET™

A combination of majestic heights, graceful arches and superior wind resistance, The AerationJet is the ideal overall water feature with heavily aerated jets reaching 50' high and spreading to 60' diameter. The AerationJet provides a dramatic effect to any lake.

Powered by a U.L. listed heavy-duty submersible turbine pump, the AerationJet standard equipment includes a complete U.L. listed control panel.

All fountain components are fully waterproof and made of the finest corrosion resistant materials to provide years of dependability and high performance.

FEATURES

FLOTATION

- ◆ U.V. resistant rotocast unit
- ◆ Four seamless, water-tight compartments for ballast
- ◆ Brass fillplugs
- ◆ Five-year warranty

CONTROL PANEL

- ◆ U.L. listed per National Electrical Code
- ◆ Weatherproof steel enclosures

CABLE

- ◆ STW-A rated, U.L. listed underwater cable

PUMPS

- ◆ High performance submersible turbines provide years of dependability and service
- ◆ Franklin stainless steel sealed motors

NOZZLE

- ◆ Brass/bronze precision machined Aeration nozzles

CORROSION RESISTANT

- ◆ Cast brass/bronze nozzles
- ◆ Rotocast float
- ◆ Stainless steel frame and fastenings
- ◆ Bronze/copper lights

LIGHTS

- ◆ Cast bronze/copper housing
- ◆ Stainless steel brackets
- ◆ Neoprene gaskets
- ◆ Tempered lenses
- ◆ Bronze/stainless steel lens protectors

BENEFITS TO LAKE

- ◆ Aesthetics — beautifies waterway
- ◆ Increases property value and quality of community
- ◆ Adds decor to community
- ◆ Assists in aeration of lake system, aiding in fish dynamics
- ◆ Through agitation, prevents aggregation of planktonic algae on the surface and helps in reduction of mosquito larvae

AERATIONJET™

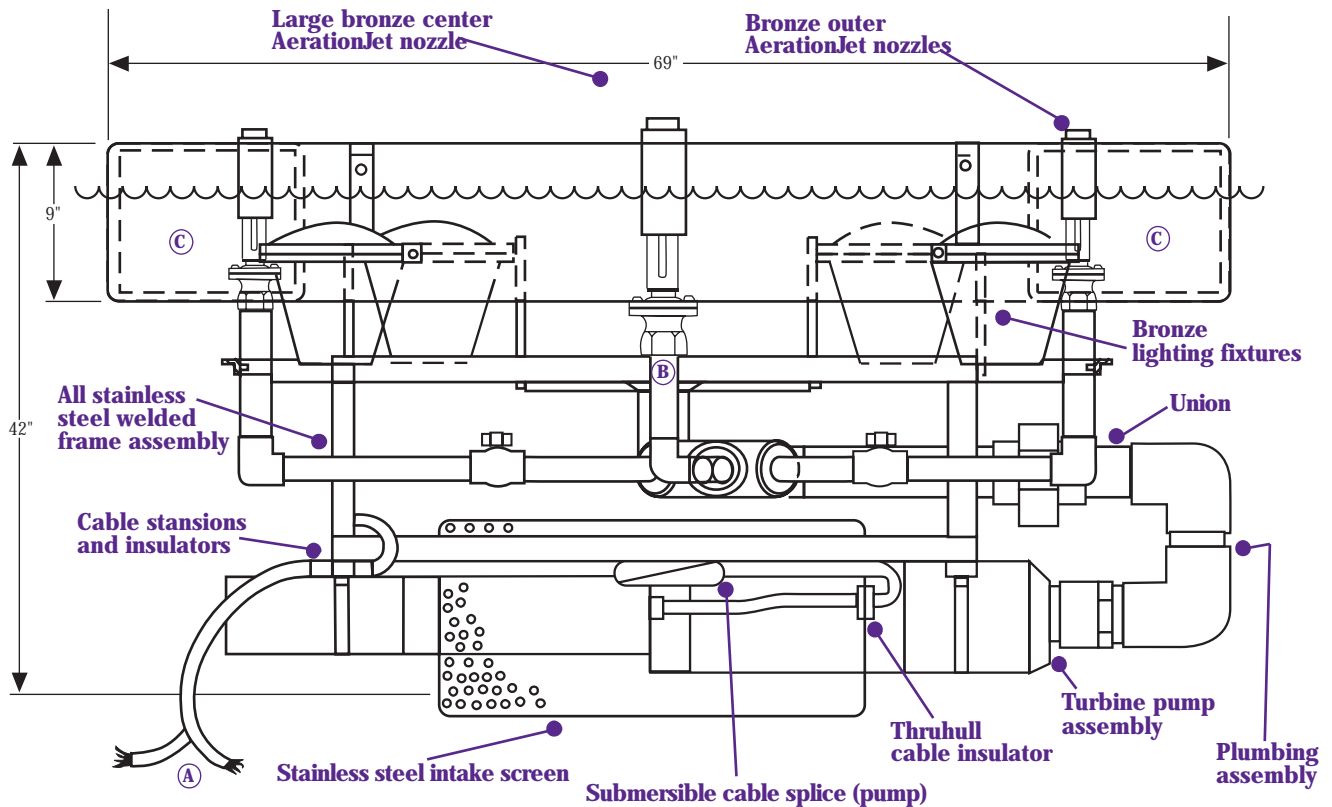

- | | |
|---|---|
| A | STW-A submersible cable (pump & lights) |
| B | Bronze submersible junction box (lights) |
| C | (4) separate ballast compartments with brass fill plugs |

DISPLAY SPECIFICATIONS

HP	CENTER HT	# SIDE HT	# SIDE JETS	# LIGHTS	TOTAL WATTAGE	AVAIL. PHASE
5	20'	10'	6	8	4000w	1,3
7,5	25'	12'	6	8	4000w	1,3
10	30'	15'	6	8	4000w	1,3
15	35'	20'	8	9	5000w	1,3
20	40'	20'	8	9	5000w	3
30	50'	25'	8	9	5000w	3

LIGHTING SPECS

Total Wattage	500	1000	1500	2000	2500	3000	3500	4000
AMP Draw	5	10	15	20	25	30	35	40

PUMP AMPERAGE (208V MOTORS AVAILABLE)

HP	230v1Ø	230v3Ø
5	28	17
7,5	42	25
10	51	32
15	72	47
20	-	61
30	-	94

Because of the electric equipment involved, floating fountains are not designed for waterways where swimming or water sports are permitted. Specifications recorded during calm wind conditions.

Install all electrical equipment in accordance with Article 680 of the National Electrical Code and all local codes. Vertex Water Features reserves the right to improve and change our designs and/or specifications of our fountains without notice or obligation.

© 2005 Vertex Water Features



Vertex Water Features

Lake Aeration Systems & Floating Fountains

2100 NW 33rd Street / Pompano Beach, FL 33069

(800) 432-4302 / Fax (954) 977-7877

www.vertexwaterfeatures.com / e-mail: info@vertexwaterfeatures.com